

Floor-Type Reversible Dough Sheeter

PROMIX

Model FDS-520



The PROMIX FDS-520 Dough Sheeter offers simplicity to dough and pastry sheeting and is good for bakeries with confined spaces. It is manually lever and foot-switch controlled with dual directional conveyor belt.

Features:

- Heavy duty aluminium alloy head housing
- Equipped with high-strength fibre conveyor belt, oil-proof and in comply with hygiene standards
- Manual adjustment of sheeting thickness between 3-30mm
- The dough thickness handgrip has a locking scale with an adjustable final thickness stopper
- Fitted with interlocked guards to both sides of the machine to ensure operator safety
- Roller speed is app. 540mm per second
- Removable scrappers provide for easy cleaning
- After use, the table can easily be folded up to minimize the space when not in use.

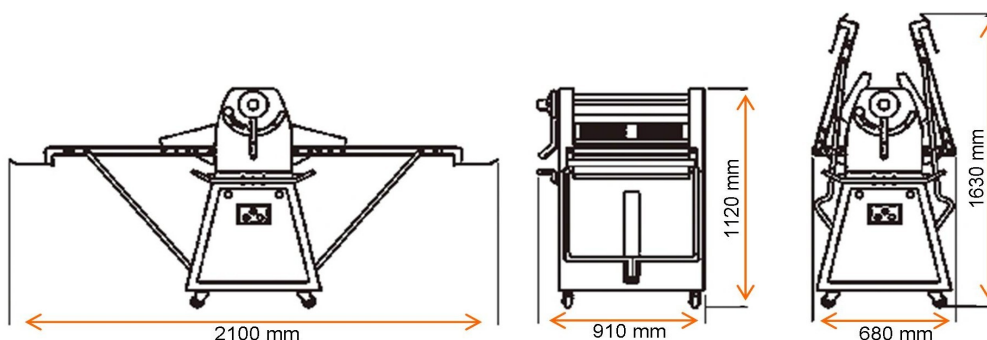

Model	Belt Size W x D (mm)	Table size (mm)	Voltage (V)	Power (HP)	Dimensions WxDxH (mm)	Weight (KG)
FDS-520	520 x 2000	970	400	1	2100x910x1120	176